

**MICROSOUND**

**SLSI-80-77**

**School Intercom System**

**Instruction Manual**

## CONTENTS

1.	General Description	3
2.	Applications	3
3.	Operation	3
4.	Installation	3
5.	Facilities	4
6.	Dialling	5
7.	Operating Instructions	5
8.	Call-backs (Auto answer mode)	5
9.	Call-backs (Non auto answer mode)	6
10.	Group calls	6
11.	General tones	6
12.	Period tones	6
13.	Evacuation tone	6
14.	All-call	6
15.	Setup	7
16.	Setup dialling lookup table	8
17.	Connector Strip Wiring For Four Master Stations & LCD Displays	9
18.	Master Station Wiring	10
19.	Reassurance Substation Wiring	12
20.	Time Switch Wiring (TS631)	12
21.	Cpu / Audio card Set-up	13
22.	Sub Card	14
23.	Diagnostics	14
24.	First Line Service	14
24.1	Installation faults	14
24.2	After installation faults	15
24.3	Testing the display and wiring	15
24.4	Testing the subcard	15
24.5	Testing the CPU card	15
25.	Software	15
26.	SLSI80 Recommended service kit	16
26.1	Complete cards	16
26.2	SLSI CPU/Audio card	16
26.3	SLSI Sub card	16
26.4	SLSI Power Supply	16
27.	Technical Specifications	16
27.1	Installation	16
27.1.1	Master station.	16
27.1.2	Display	16
27.1.3	Sub station.	16
27.1.4	P.A. Speakers.	17
27.2	Audio Specifications	17
28.	Mechanical	17
29.	Guarantee	17

Revised 14 September 2010

## 1. General Description

The SLSI-80 is a fully electronic exchange with microprocessor control. It is compact and has relay switching for reliable audio control.

The SLSI-80 consists of four basic sections. Central processing unit (CPU), Master Sub card, Sub card and Power supply (PSU). The CPU consists mainly of the microprocessor, memory, audio amplifier, tone generator and control functions.

The 30w-rms amplifier can drive up to 120 standard sub stations before a booster amplifier is needed.

The power supply module has outputs of 10V, 24V and 42V. The SLSI-80 operates on 220/250V AC. It is designed for wall mounting for space conservation.

## 2. Applications

Schools, Old Age Homes, Fire Stations, Toll Roads, Fire Systems, Hospitals, Low Cost Housing, Apartments, Hostels, Pay on Foot Parking etc.

## 3. Operation

The SLSI-80 intercom can dial any of the sub stations individually, in a group or all together (all-call). If a call back (button on the sub station) is made the system will automatically answer to the master. To redirect a call back to a different master station 980 must be dialled at that master station. If more than one call back is made at the same time the numbers will be stacked and the display will indicate call waiting. All the numbers in the system can be stacked at the same time. The lowest number will always be answered first.

The software can be configured for different systems. Eg: Old Age Homes, Hospitals, and various other installations on site via a master station in the programming mode.

## 4. Installation

Pay particular attention to the following points during installation of the exchange. Failure to do so will invalidate the guarantee.

The layout should allow for easy servicing and inspection.

Avoid installing the unit where it may be affected by vibrations.

Choose a low "source noise" AC power supply for the exchange.

Care must be taken to leave space above the SLSI80 as the cover comes off the top.

All installations must have separate cables for Master, Sub stations and displays.

Cable joints must never be made in ceilings or in inaccessible places, joints should be made in easily accessible DP boxes or in sub stations.

All systems have a 220/250v primary winding on the mains transformer, check your mains voltage.

Before switching on, check all cables for shorts and earth faults.

Always switch power off before unplugging PCB cards.

Audio cable must be twisted pair cable.

Do not install system in a cupboard. Ensure sufficient air flow around the system.

Unplug mains when working on power supply PCB as there is mains present even after switching power off.

Never install intercom cable anywhere near P.O. telephone cable or in P.O. cable. (lightning hazard).

Never use pairs in multicore cable which carry other audio, music or signals which might cause interference.

Sub stations are polarized, the sub must only be connected one way, with the positive wire to the positive side of the capacitor in the sub station. (Blue + , White -).

Never slot different thickness cable into the same slot on the Krone strips.

Central Exchange must be mounted vertically.

The Krone insertion tool must be used to terminate the cables on the Krone modules.

A screened cable must be used for the display if there is a possibility that it can be subjected to lighting.

If sub station cables and master station cables have to run in the same conduit, channelling or sleeves the master station cable must be a screened cable with its screen earth at the central to prevent induction from the sub station cable. Sub and master station cables must be kept separate as far as possible.

## **5. Facilities**

Master to master dialing.

Master to sub calls.

Master to handset.

Master to P.A. calls.

Eight group calls.

All call.

Auto cancel. (5 minutes adjustable)

Auto answer or non auto answer call backs.

Two change of period tones.

General tone.

Evacuation tone.

Special Numbers.

Programming mode.

## 6. Dialling

Function	Version 1	Version 2
Master to master call	001 - 004	981 – 984
Version select	*09	*10
Substations	005 – 192	001 – 192
First group	970	970
Second group	971	971
Third group	972	972
Fourth group	973	973
Firth group	974	974
Sixth group	975	975
Seventh group	976	976
Eighth group	977	977
Change main master	980	980
Slow beep tone	993	993
Fast beep tone	994	994
Three beep tone	995	995
Activate period tone 1	996	996
Activate period tone 2	997	997
Activate evacuation tone	998	998
All call	999	999
Talk to the sub station	*	*
Cancelling a call	#	#

## 7. Operating Instructions

Any three digit number from 001 to 999 can be dialed. The low numbers are generally to dial other master stations while the numbers above 980 are special functions. The number list will indicate the number to dial for the special functions available on the SLSI-80.

After the first digit is dialed the busy light will light and a beep will be heard to indicate that the button has been accepted. The SLSI-80 will now wait for a second digit to be dialed. At any point the cancel button "#" on the master station keyboard can be pressed and the dialing restarted. When the second digit is dialed a beep will be heard again and then a "call-tone" will go through to that number dialed to announce that a call has been made. The operator will now be able to listen to that area.

When the operator wants to speak, the "T" (talk) button (marked as "\*" on the keyboard) must be pressed and released when the operator wants to listen.

To terminate the conversation the cancel button must be pressed. The call will automatically be cancelled after a duration of 30 seconds to allow other users' call-backs to be processed.

There are no beeps when operating the "T" button or cancel. The light will go off whenever the cancel button is pressed if the call is made from that station.

## 8. Call-backs (Auto answer mode)

When a callback is made from a sub station a callback tone will be heard at the main master station and at the sub station from where the call-back is been made. Immediately the person making the callback will be heard at the main master station. (This is ideal for emergencies).

If at the time of making a callback the SLSI-80 is busy, the callback will go through when the call in progress is cancelled or the auto time-out facility cancels the call. Only at this point will the callback tone go though to the sub station and to the main master station.

If more than one call-back is made at the same time or while a call is in progress, the sub or master station with the lowest number will be answered first (in this way sub stations with lower numbers have a higher priority).

The main master (the master the callback is directed to) can be changed by dialing 980 on the master to which the callback's are directed too.

**9. Call-backs (Non auto answer mode)**

When the non auto answer is enabled the number calling back is displayed on all the displays and the buzzer sounds. Any master station can then dial that number, the buzzer will stop and the master can communicate with the sub. If a second call back is made at the same time, call waiting is displayed on the display.

**10. Group calls**

There are eight group calls 970 – 977. The numbers in any of the groups can be set to suit the client's requirements in the programming mode. Press the 'T' button to talk.

**11. General tones**

There are three general tones 993 – 995. All the sub stations will be selected during 'General tones'. The duration will be the same as set for Cperiod1.

**12. Period tones**

There are two period tones. 996 and 997. The numbers in the group 8 and 9 can be set in the programming mode. The tones can also be triggered on the krone strip 0 pair 3.

**13. Evacuation tone**

When a Evacuation tone 998 is dialed a evacuation tone will be received at all the Master and Sub stations connected to the system.

**14. All-call**

When all-call is dialed it is necessary to press the "T" button, to be in forward speech mode. All-call includes all masters and subs.

## 15. Setup

000	Lock / Unlock No changes can be made to the setup before the system is unlocked	970	Group 0
*01	Shows the software version	971	Group 1
*02	Lock / Unlock	972	Group 2
*03	Shows the number of master stations	973	Group 3
*04	Shows the number of sub cards	974	Group 4
*05	Enable / Disable auto answer	975	Group 5
*06	Display main master (call back master)	976	Group 6
*07	LCD buzzer enable / disable (only with no auto answer)	977	Group 7
*08	Enable / Disable dial lookup (use this mode for testing the hardware)	978	Group 8 Change period tone 1
*09	Reset dialling lookup to Version 1 defaults (8085 based cpu card) first sub station # 005	979	Group 9 Change period tone 2
*10	Reset dialling lookup table to factory defaults Version 2 (PIC16F877 based cpu card) first sub number # 001	980	Main master
		981	Master Station
*12	Setup dialling lookup table	982	Master Station
	# to dial xxx, Calling relay # xxx	983	Master Station
	Press "*" to enter	984	Master Station
*13	Using reassurance sub stations	985	Master Station (optional)
*14	Time out time in seconds	986	Master Station (optional)
*15	Call tone durations duration	987	Master Station (optional)
*16	Change of period tone 1 duration	988	Master Station (optional)
*50	Sets up group 0. Enter the first relay number you want to change (3 digits). Press "*" to step to next relay number. Press "7" to step back. Press "0" to clear, Press "1" to set relay number "on". Press "#" to exit out of group setup.		
*51	Sets up group 1	993	Slow beep tone
*52	Sets up group 2	994	Fast beep tone
*53	Sets up group 3	995	Three beep tone
*54	Sets up group 4	996	Change of period tone 1
*55	Sets up group 5	997	Change of period tone 2
*56	Sets up group 6		
*57	Sets up group 7	998	Evacuation tone
*58	Sets up group 8 Change period tone 1		
*59	Sets up group 9 Change period tone 2	999	All call
*60	Clears group 0		
*61	Clears group 1	*	Press to talk
*62	Clears group 2	#	Cancel
*63	Clears group 3		
*64	Clears group 4		
*65	Clears group 5		
*66	Clears group 6		
*67	Clears group 7		
*68	Clears group 8 Change period tone 1		
*69	Clears group 9 Change period tone 2		
*70	Sets group 0 on		
*71	Sets group 1 on		
*72	Sets group 2 on		
*73	Sets group 3 on		
*74	Sets group 4 on		
*75	Sets group 5 on		
*76	Sets group 6 on		
*77	Sets group 7 on		
*78	Sets group 8 on Change period tone 1		
*79	Sets group 9 on Change period tone 2		

## 16. Setup dialling lookup table

Sub	Number	Sub	Number	Sub	Number
1		41		81	
2		42		82	
3		43		83	
4		44		84	
5		45		85	
6		46		86	
7		47		87	
8		48		88	
9		49		89	
10		50		90	
11		51		91	
12		52		92	
13		53		93	
14		54		94	
15		55		95	
16		56		96	
17		57		97	
18		58		98	
19		59		99	
20		60		100	
21		61		101	
22		62		102	
23		63		103	
24		64		104	
25		65		105	
26		66		106	
27		67		107	
28		68		108	
29		69		109	
30		70		110	
31		71		111	
32		72		112	
33		73		113	
34		74		114	
35		75		115	
36		76		116	
37		77		117	
38		78		118	
39		79		119	
40		80		120	

## 17. Connector Strip Wiring For Four Master Stations & LCD Displays

Pair	1		2		3		4		5		6		7		8	
Strip	+	-	+	-	+	-	+	-	+	-	+	-	+	-	+	-
Krone	A	B	C	D	PR1	PR2	ENG	GND	A	B	C	D	S1	S2	S3	O/P
0	Master station connections				Master station				LCD Display							
	M3	M4	M5	M6	T1	T2	M7	M8	L1	L2	L3	L4	L5	L6		B1
	Common to all masters				Common											

Master sub card wiring. See next page for details.

Krone	/----- Master station wiring -----\								/----- Sub stations on master sub card wiring -----\								
1	+ 1 -	+ 2 -	+ 3 -	+ 4 -	+ 5 -	+ 6 -	+ 7 -	+ 8 -									
	M1 + M2		M1 + M2		M1 + M2		M1 + M2										
Krone	1st master		2nd master		3rd master		4th master		/----- Sub stations on master sub card wiring -----\								
2	NC	NC	NC	NC	+ 9 -	+ 10 -	+ 11 -	+ 12 -									

Krone	Subcard # 1 --- Switches 10000011 --- sub station wiring 13 – 28							
3	+ 13 -	+ 14 -	+ 15 -	+ 16 -	+ 17 -	+ 18 -	+ 19 -	+ 20 -
Krone	/----- Sub station wiring -----\							
4	+ 21 -	+ 22 -	+ 23 -	+ 24 -	+ 25 -	+ 26 -	+ 27 -	+ 28 -

Krone	Subcard # 2 --- Switches 01000011 --- sub station wiring 29 – 44							
5	+ 29 -	+ 30 -	+ 31 -	+ 32 -	+ 33 -	+ 34 -	+ 35 -	+ 36 -
Krone	/----- Sub station wiring -----\							
6	+ 37 -	+ 38 -	+ 39 -	+ 40 -	+ 41 -	+ 42 -	+ 43 -	+ 44 -

Krone	Subcard # 3 --- Switches 11000011 --- sub station wiring 45 – 60							
7	+ 45 -	+ 46 -	+ 47 -	+ 48 -	+ 49 -	+ 50 -	+ 51 -	+ 52 -
Krone	/----- Sub station wiring -----\							
8	+ 53 -	+ 54 -	+ 55 -	+ 56 -	+ 57 -	+ 58 -	+ 59 -	+ 60 -

Krone	Subcard # 4 --- Switches 00100011 --- sub station wiring 61 - 76 (last card in 6 way controller)							
9	+ 61 -	+ 62 -	+ 63 -	+ 64 -	+ 65 -	+ 66 -	+ 67 -	+ 68 -
Krone	/----- Sub station wiring -----\							
10	+ 69 -	+ 72 -	+ 71 -	+ 72 -	+ 73 -	+ 74 -	+ 75 -	+ 76 -

Krone	Subcard # 5 --- Switches 10100011 --- sub station wiring 77 – 92							
11	+ 77 -	+ 72 -	+ 79 -	+ 80 -	+ 81 -	+ 82 -	+ 83 -	+ 84 -
Krone	/----- Sub station wiring -----\							
12	+ 85 -	+ 72 -	+ 87 -	+ 88 -	+ 89 -	+ 90 -	+ 91 -	+ 92 -

Krone	Subcard # 6 --- Switches 01100011 --- sub station wiring 93 – 108							
13	+ 93 -	+ 72 -	+ 95 -	+ 96 -	+ 97 -	+ 98 -	+ 99 -	+ 100 -
Krone	/----- Sub station wiring -----\							
14	+ 101 -	+ 72 -	+ 103 -	+ 104 -	+ 105 -	+ 106 -	+ 107 -	+ 108 -

Krone	Subcard # 7 --- Switches 11100011 --- sub station wiring 109 - 124 (Last card in 9 way controller)							
15	+ 109 -	+ 72 -	+ 111 -	+ 112 -	+ 113 -	+ 114 -	+ 115 -	+ 116 -
Krone	/----- Sub station wiring -----\							
16	+ 117 -	+ 72 -	+ 119 -	+ 120 -	+ 121 -	+ 122 -	+ 123 -	+ 124 -

## 18. Master Station Wiring

RJ45 Socket	Function
M1	Master station audio pair (from krone strip 1)
M2	Master station audio pair (from krone strip 1)
M3	Dialling line A (Common to all masters) (from krone strip 0)
M4	Dialling line B (Common to all masters) (from krone strip 0)
M5	Dialling line C (Common to all masters) (from krone strip 0)
M6	Dialling line D (Common to all masters) (from krone strip 0)
M7	Engaged line (Common to all masters) (from krone strip 0)
M8	Ground (Common to all masters) (from krone strip 0)

Each Master Station installed must have its own separate 5-pair cable installed back to the Controller. The common wires M3 to M8 must only be common at the Controller. The spare pair of the 5 pair must be used for M8 to thicken up the Ground to reduce voltage drop. The maximum cable length to the Master Station is 200m. If the Master Station is more than 200m away, a separate power supply (MPS-2405) must be installed at the master. If a separate power supply is used, the +24V from the Controller must be disconnected from the Master socket and the +24V from the power supply connected. The grounds must be common. If more than one Master is installed the commons M3 to M8 must be common in a connector block at the Controller then with a single core pumped into the Krone connector.

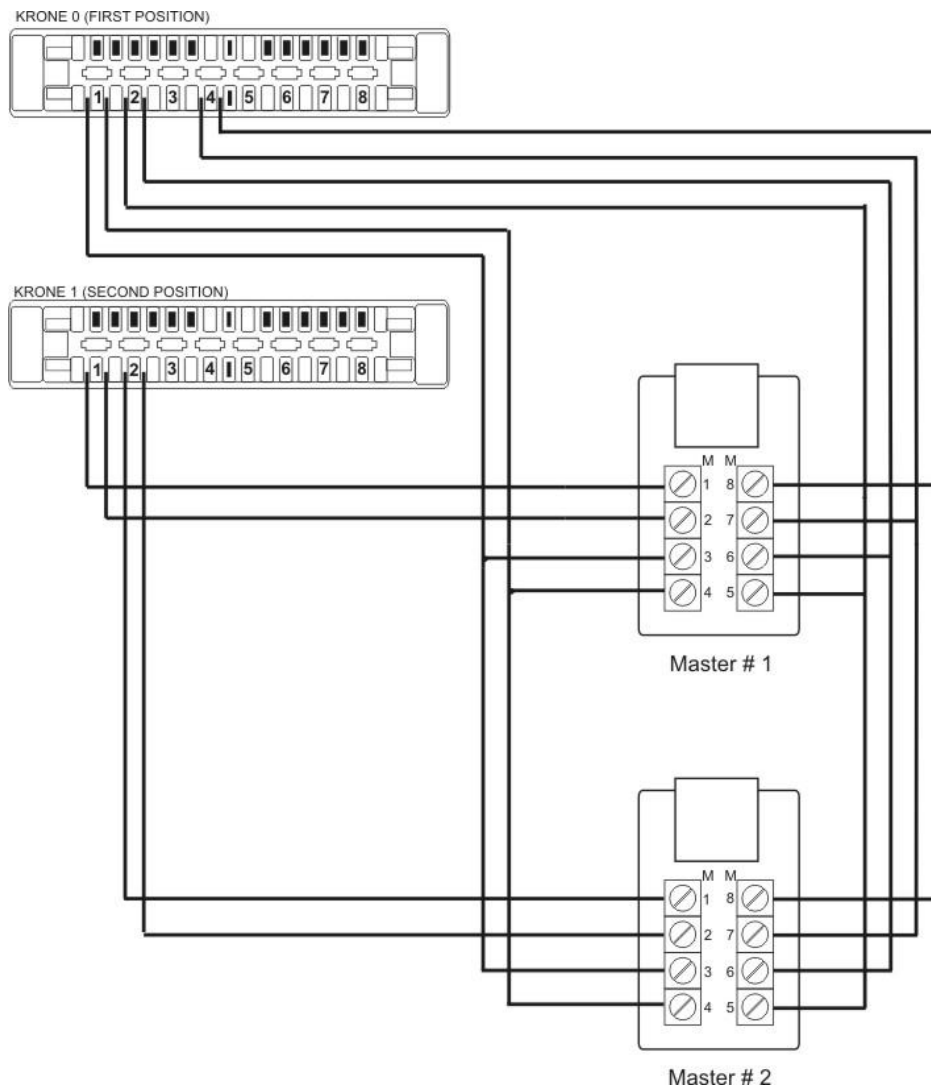

## 19. LCD Display Wiring

RJ11 Socket	Controller Connections	Function
+	Power supply Display +24V	Supply +24V 1 pair
-	Power supply Display Ground	Ground 1 pair
L1	Krone 0 pair 5 +	RS 485 +
L2	Krone 0 pair 5 -	RS 485 -

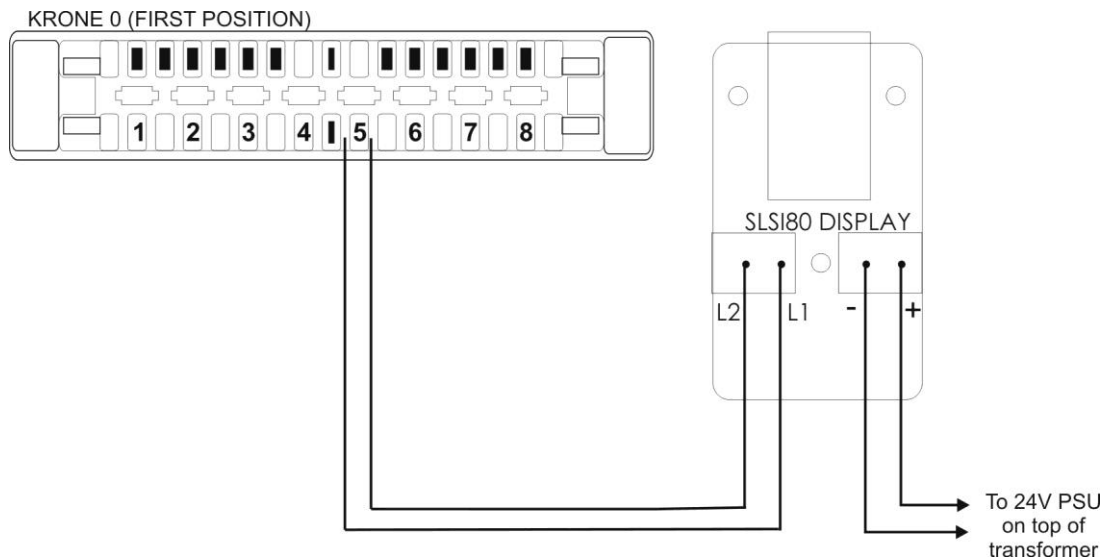

NB.

The LCD Display must be wired in series (not star) with the last display socket having a 120E resistor terminating the RS 485 pair, across L1 and the L2 wires. We recommend the resistor be placed in the Display socket. If the display is unplugged it will not affect the other displays.

## 19. Reassurance Substation Wiring

Requires a separate 24v power supply, and a common positive and negative to each sub station plus a individual intercom pair to each sub station.

Reassurance substation PCB (component view)

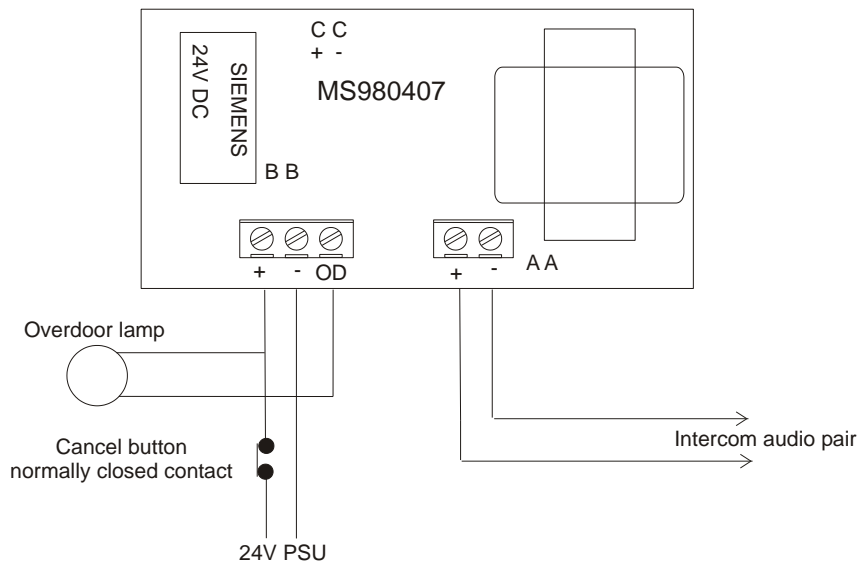

## 20. Time Switch Wiring (TS631)

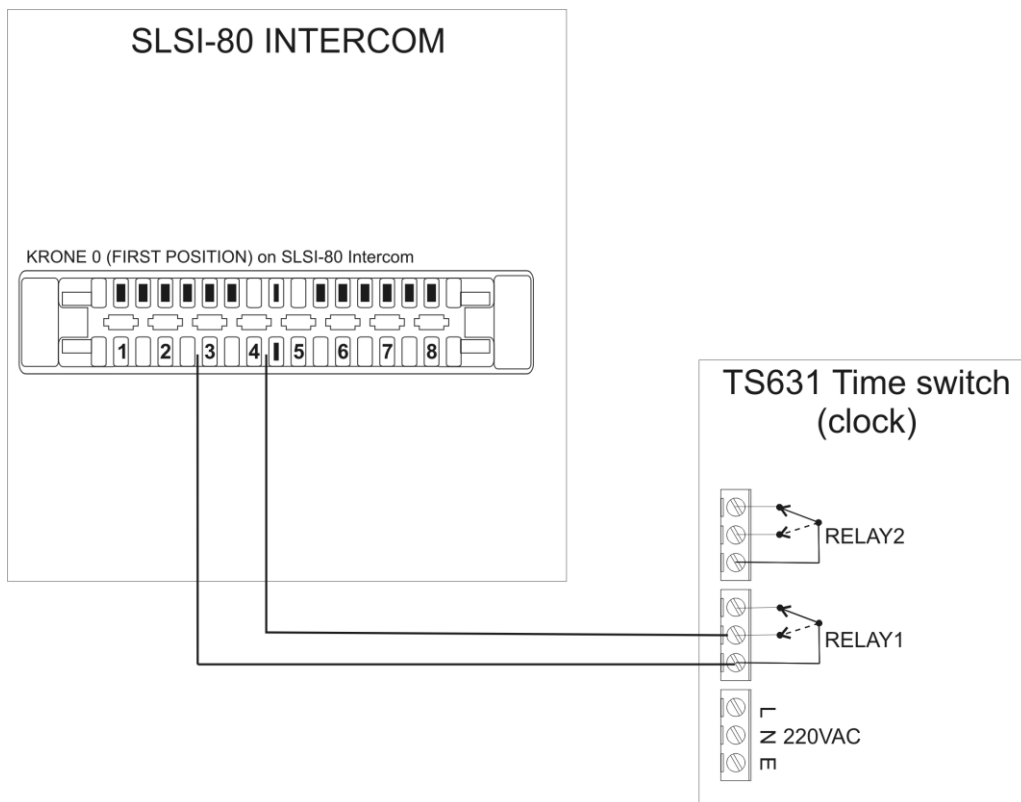

## 21. Cpu / Audio card Set-up

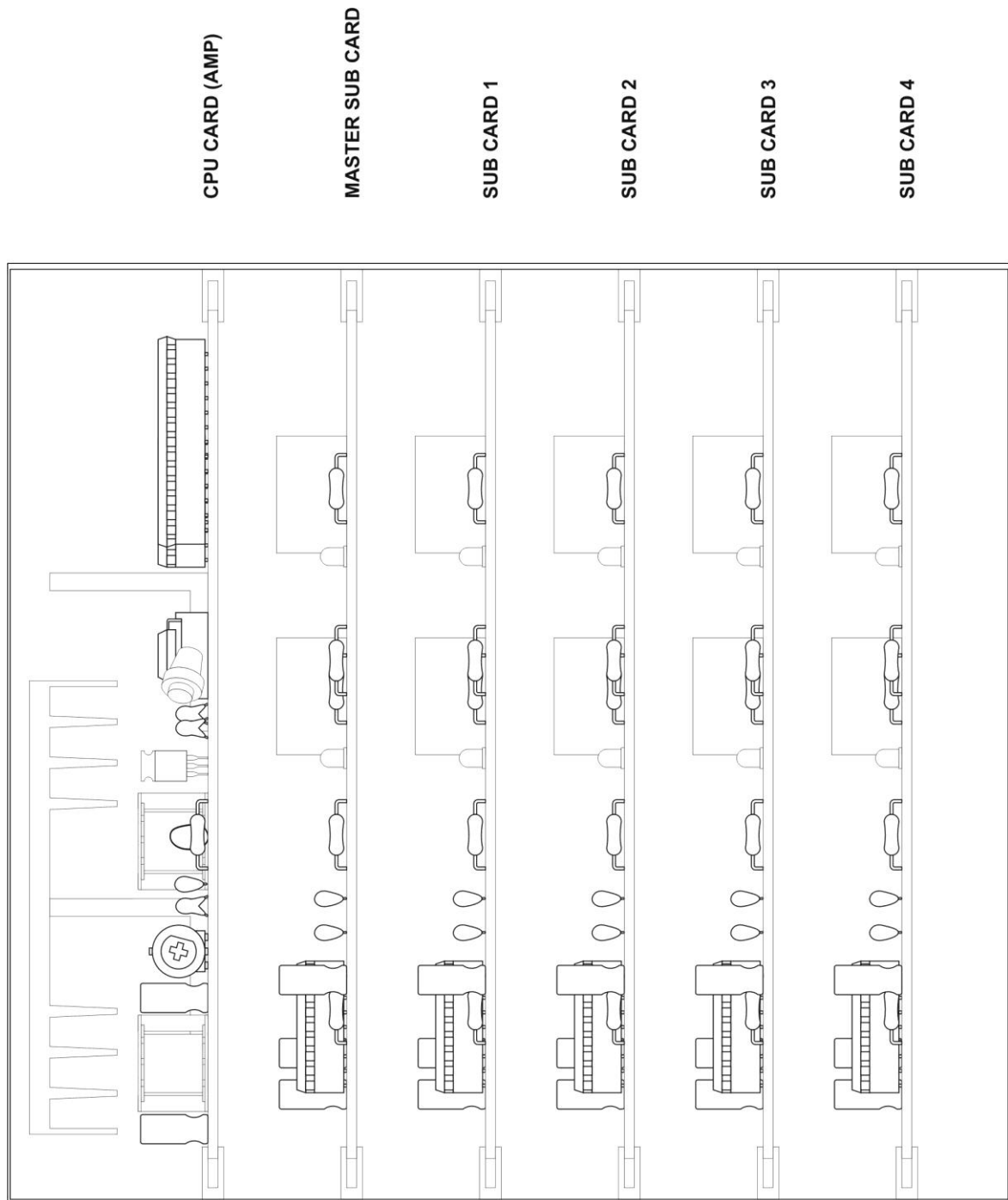

All CPU cards are identical.

P1 - Audio level.

P2 - Tone level.

The period tones can be activated by dialling or by switching strip 0 (pin 5 and 6) to ground (Strip 0 pin 8) via a switch or relay.

## 22. Sub Card

The systems are factory wired for a specific number of Master and Sub stations.

The first Sub card (Master sub card) will always be wired for a combination of Master and Sub stations and can not be swapped with any other sub card. The first sub card cannot be swapped with that of a different system unless both systems have the same combination of master stations. The master station relays must have the ground removes. A master sub card can be identified by the two wire links, which are usually installed after the number of masters stations the system is configured for.

Each sub card has a eight way dip switch to select its address.

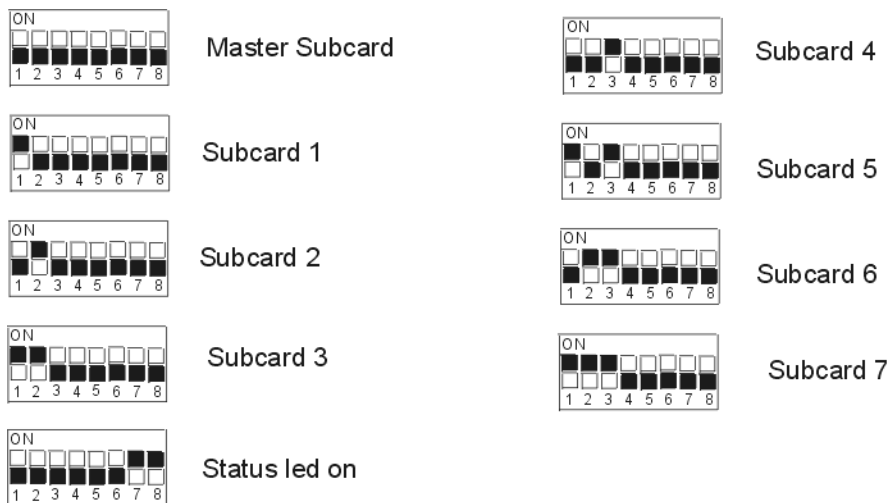

## 23. Diagnostics

It is recommended that a Test jig, Krone Tool, Multimeter, Impedance meter and disconnect plugs are available when installing or fault finding a SLSI80 system.

When the system is first switched on 'SLSI-80 Ver x.xx' will be display on the LCD display. This number will remain there until all the callbacks are cleared. If there are no callbacks this should only last for a few seconds.

Should you have any questions please do not hesitate to contact Microsound Systems.

## 24. First Line Service

### 24.1 Installation faults

#### 1. The master station dials a wrong number

Check the master station dialling leads.

Check that the subcards are on the correct addresses.

Make sure you have the software that you expect to have.

#### 2. A sub station keeps calling back

Check the substation polarity. You can measure the voltage (5 volts DC, only if there is no audio) at the substation. The polarity is indicated on the capacitor (100uF 16v). If a horn is used a capacitor must be in series.

### **3. Blows fuse when doing an all call**

Probably a short on one of the substations.

The system will work with a load of approximately 2.5 ohms. Check that the impedance is about 300 ohms on each substation line. (This is highly recommended). If you do not have a impedance meter speak to your manager to get you one and start unplugging subcards. You will have to keep replacing the fuse on the CPU card under the heat sink.

## **24.2 After installation faults**

### **1. System is completely dead**

Check all four fuses and the power supply. If this is all ok the CPU card is probably dead.

### **2. Master station only dials one digit**

Check the fuse on the CPU card under the heat sink. If a beep was heard as you pressed the number this usually indicates that the audio amp is working. Check that one of the dialling leads is not stuck down.

## **24.3 Testing the display and wiring**

This is very difficult as the micro writes to the display quite fast. One way is to use a scope. There must be  $\pm 2V$  across the RS485 pair when any number is dialled. The pair must be terminated at the end.

The dialling can be checked by any number and checking the correct number appears on the display. If incorrect check the following.

All the dialling leads (ABCD - pins 3, 4, 5, 6 of the master plug or Krone strip 0 pairs 1,2) should measure 5v to ground.

When you press "1" on the master keypad dialling lead A should go low while BCD should remain high.

When you press "2" on the master keypad dialling lead B should go low while ACD should remain high.

When you press "4" on the master keypad dialling lead C should go low while ABD should remain high.

When you press "8" on the master keypad dialling lead D should go low while ABC should remain high.

## **24.4 Testing the subcard**

Never swap a master sub-card with a sub-card.

Swop the sub-card with a working sub-card, change the address. If you want to prevent call backs remove the 74HC240 on the sub-card. There are eight call backs on each 74HC240. Make sure you only use factory approved components.

## **24.5 Testing the CPU card**

Very little one can do in the field about repairing one of these. If the display displays "SLSI-80 VER xx.xx" display when the system starts up, this usually indicates the CPU is running.

## **25. Software**

Make sure the software is correct for the chassis and master sub card. This is very important. A master sub card can be identified by the two wire links between the relays. Start counting relays from the top right corner to the wire links and this will indicate the number of masters the card is configured for.

25 April 2005

'SLSI-80 Ver 1.19'

## 26. SLSI80 Recommended service kit

### 26.1 Complete cards

1 x SLSICPU77000	CPU/Audio card
1 x SLSIMSBCB400	Master sub card
1 x SLSISUBCB000	Sub card with call back
1 x SLSIMSTL1208	Master station and display
1 x SLSI80	Power supply board
1 x SLSI80	Extender Card
1 x SLSI80	Master station / display test jig

### 26.2 SLSI CPU/Audio card

U1	PIC16F877
U2	24LC65
U3	SN75176
U4	LF353
Fs1	5 amp fuse

### 26.3 SLSI Sub card

U1,2	74HC240
U3	74HC688
U4	74HC138
U5,6	74HC374
U7,8	ULN2803A

### 26.4 SLSI Power Supply

F1	1 Amp Fuse
F2	5 Amp Fuse
F3	2 Amp Fuse

## 27. Technical Specifications

### 27.1 Installation

Mains Supply 220/250V AC 150 VA.

#### 27.1.1 Master station.

- All wiring on 0,5mm twisted pair telephone cable.
- 2 Common dialling pairs to all master stations.
- 1 Common ground line to all master stations.
- 1 Common engaged line to all master stations.
- 1 Individual audio pair to each master station.

#### 27.1.2 Display

- All wiring on 0,5mm twisted pair telephone cable.
- 1 Common pair +24V.
- 1 Common pair GND.
- 1 Common pair for RS485 terminated at the end with 120E resistor.

#### 27.1.3 Sub station.

- All wiring on 0,5mm twisted pair telephone cable.
- 1 Individual pair to each sub for audio and call-back.
- 1 Common positive pair to all subs if a reassurance lamp is needed at the sub station.

#### **27.1.4 P.A. Speakers.**

All wiring on 0,5mm twisted pair telephone cable.  
1 Individual audio pair to each point.

#### **27.2 Audio Specifications**

Acoustical output of master station	70 dB(A)
Acoustical output of sub station	73 dB(A)
Frequency response	400Hz - 5KHz
Max distortion	less than 1%
Signal to noise ratio	-55 dB
Amplifier output	30 watts continuous
Audio input and output is balanced.	

#### **28. Mechanical**

Weight of central is 20 kg.  
Dimensions (SLSICABPSC06) 480 mm height.  
330 mm wide.  
210 mm deep.

Dimensions (SLSICABPSC12) 660 mm height.  
450 mm wide.  
275 mm deep.

Cards are standard EURO, 4U x 220 mm, through hole plated, solder masked pc boards.  
Cards plug into backplane motherboard.  
PCB connectors are DIN 41612.  
Modular system allows easy maintenance.

#### **29. Guarantee**

Equipment is guaranteed by the manufacture for a period of six months from the date of delivery against faulty components and workmanship. ex Factory.

Manufactured by:  
Microsound Systems cc  
P.O. Box 38220  
Booyens  
2016  
Phone 011 493 2424  
Fax 011 492 0347  
Email [sales@microsound.co.za](mailto:sales@microsound.co.za)  
Web <http://www.microsound.co.za>

Distributed by: